

LEIPZIG-ALTENBURG AIRPORT
NDB
RWY 04

MUENCHEN RADAR 126.175
ALTENBURG INFORMATION 123.580

ELEV 640
OCH RELATED TO THR 04 ELEV 639
VAR 3° E

INSTRUMENT
APPROACH
CHART - ICAO

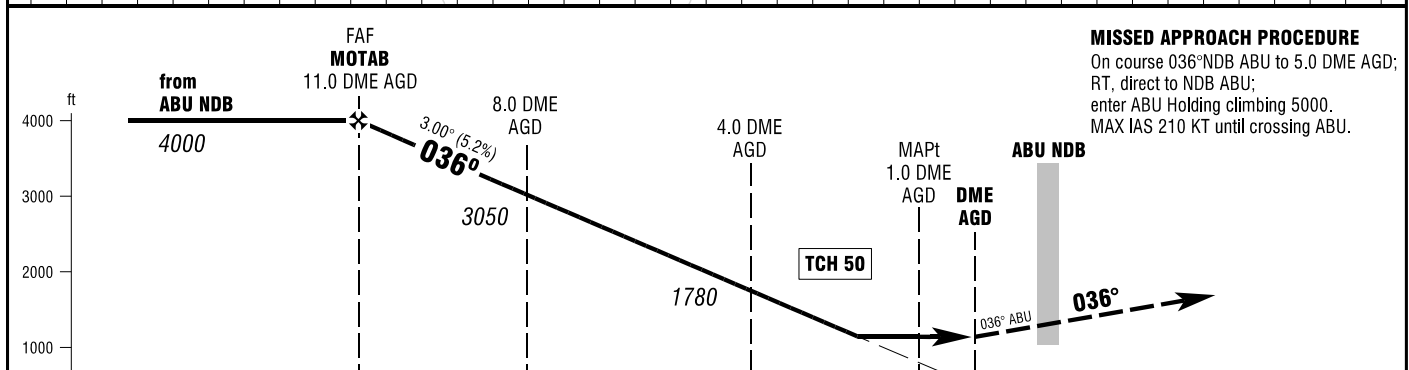
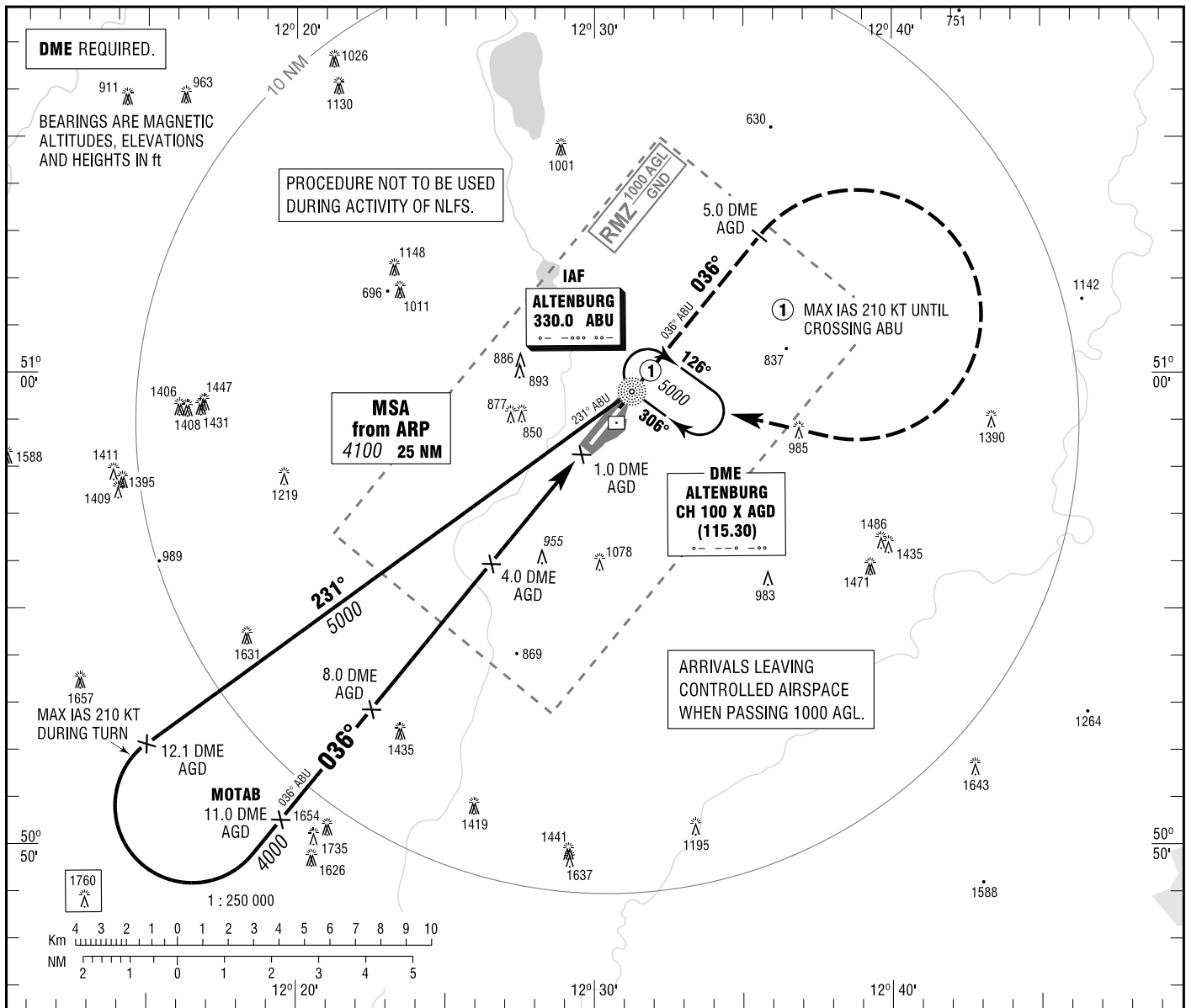

MISSED APPROACH PROCEDURE
On course 036°NDB ABU to 5.0 DME AGD; RT, direct to NDB ABU; enter ABU Holding climbing 5000. MAX IAS 210 KT until crossing ABU.

OCA (OCH)	A	B	C	D
NDB-DME	1210 (570)	1210 (570)	1210 (570)	1210 (570)

DME AGD	10	9	8	7	6	5	4	3	2
DIST THR	9.4	8.4	7.4	6.4	5.4	4.4	3.4	2.4	1.4
ALTITUDE	3660	3350	3030	2720	2400	2080	1770	1450	1140

Timing not authorized for defining the MAPt.

GS	kt	80	100	120	140	160	180
MOTAB - 1.0 DME AGD (10.0 NM)	MIN:SEC	7:30	6:00	5:00	4:17	3:45	3:20
Rate of descent (5.2%)	ft / MIN	420	530	630	740	840	950

Correction: Callsign.