

AERODROME CHART

TWR 130.0(118.85)

ZYJM JIAMUSI/Jiamusi

N46° 50.5'E130° 27.9' ELEV 79.9m

| RWY | Direction | Bearing strength |
|-----|-----------|--|
| 06 | 059° | PCR 660/R/C/W/T: RWY06/24 CONC PCR 810/R/C/W/T: TWY C PCR 670/R/C/W/T: TWY B |
| 24 | 239° | PCR 700/R/C/W/T: Stands Nr.05, 06 PCR 680/R/C/W/T: Stands Nr.01-04 |

BEARINGS ARE MAGNETIC.
ALTITUDES, DISTANCES,
ELEVATIONS AND HEIGHTS
IN METERS.

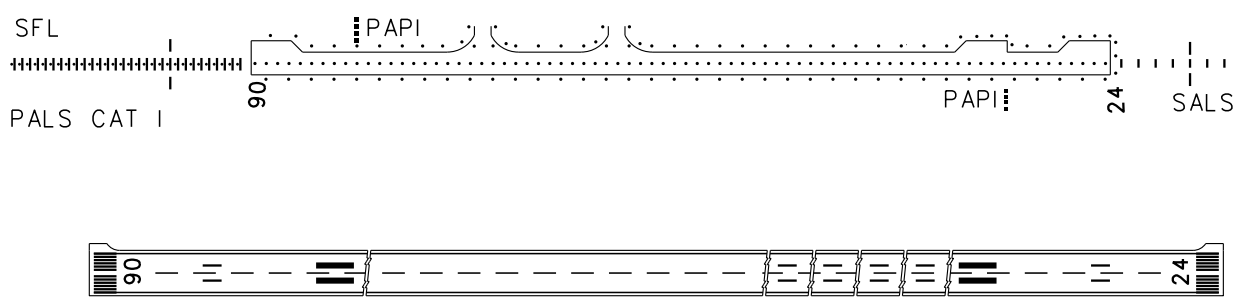
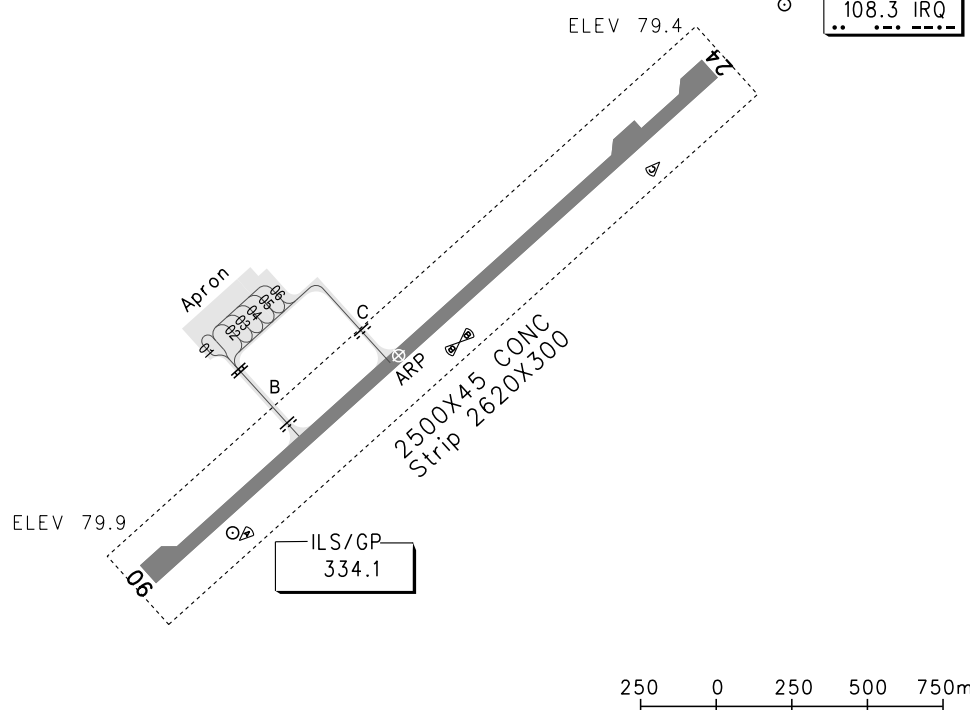

| TAKE-OFF MINIMA(WITH RELIABLE ALTN)(m) | | | | LIGHTS | | |
|--|---------|---------------|--------|---------------|---|--------------------------------------|
| ACFT Type | RWY06 | | RWY24 | | RWY06 | RWY24 |
| | REDL | NIL(Day only) | REDL | NIL(Day only) | | |
| 2 TURB ENG or 3&4 ENG | A | | | | PALS CAT I SFL PAPI REDL RCLL RENL | SALS PAPI REDL RCLL RENL |
| | B | RVR400 | RVR500 | RVR400 | | |
| | C | VIS800 | VIS800 | VIS800 | | |
| | D | | | | | |
| Other 1&2 ENG | VIS1600 | | | | | |
| Note: | | | | | | |
| Changes: PCR. | | | | | | |